

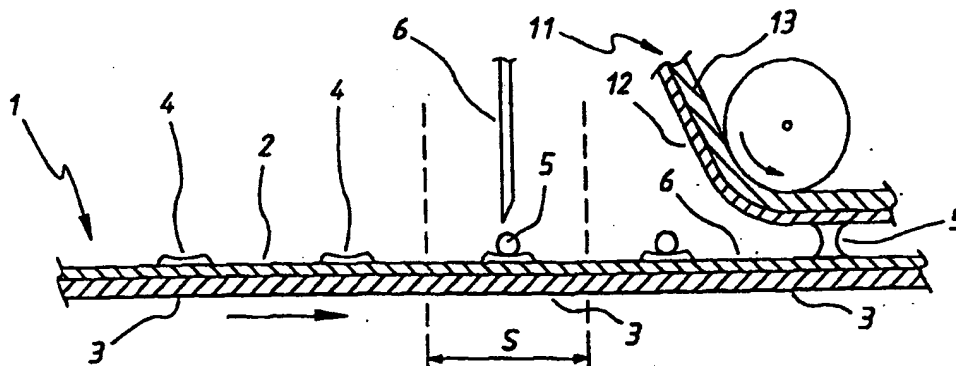

INTERNATIONAL APPLICATION PUBLISHED UNDER THE PATENT COOPERATION TREATY (PCT)

(51) International Patent Classification ⁶ : G01N 27/403, 27/49, 35/02	A1	(11) International Publication Number: WO 99/09404 (43) International Publication Date: 25 February 1999 (25.02.99)
<p>(21) International Application Number: PCT/AU98/00642</p> <p>(22) International Filing Date: 13 August 1998 (13.08.98)</p> <p>(30) Priority Data: PO 8558 13 August 1997 (13.08.97) AU</p> <p>(71) Applicant (for all designated States except US): USF FILTRATION AND SEPARATIONS GROUP INC. [US/US]; Suite 700, 9690 Deereco Road, Timonium, MD 21093 (US).</p> <p>(72) Inventors; and (75) Inventors/Applicants (for US only): MAXWELL, Ian, Andrew [AU/AU]; 22 Beaconsfield Avenue, Concord, NSW 2137 (AU). BECK, Thomas, William [AU/AU]; 121 Keda Circuit, North Richmond, NSW 2754 (AU). HODGES, Alastair, McIndoe [AU/AU]; 15 Jasmine Circuit, Blackburn South, VIC 3130 (AU).</p> <p>(74) Agent: BALDWIN SHELSTON WATERS; 60 Margaret Street, Sydney, NSW 2000 (AU).</p>	<p>(81) Designated States: AL, AM, AT, AU, AZ, BA, BB, BG, BR, BY, CA, CH, CN, CU, CZ, DE, DK, EE, ES, FI, GB, GE, GH, GM, HR, HU, ID, IL, IS, JP, KE, KG, KP, KR, KZ, LC, LK, LR, LS, LT, LU, LV, MD, MG, MK, MN, MW, MX, NO, NZ, PL, PT, RO, RU, SD, SE, SG, SI, SK, SL, TJ, TM, TR, TT, UA, UG, US, UZ, VN, YU, ZW, ARIPO patent (GH, GM, KE, LS, MW, SD, SZ, UG, ZW), Eurasian patent (AM, AZ, BY, KG, KZ, MD, RU, TJ, TM), European patent (AT, BE, CH, CY, DE, DK, ES, FI, FR, GB, GR, IE, IT, LU, MC, NL, PT, SE), OAPI patent (BF, BJ, CF, CG, CI, CM, GA, GN, GW, ML, MR, NE, SN, TD, TG).</p> <p>Published With international search report.</p>	

(54) Title: METHOD AND APPARATUS FOR AUTOMATIC ANALYSIS



(57) Abstract

A method for estimating the concentration of a reduced (or oxidised) form of a redox species in a liquid comprises contacting an area of a first electrode (2) with a sample (5) of the liquid, contacting the sample (5) with a second electrode (2) spaced apart from the first (2), applying a potential between the electrodes while the electrodes are sufficiently closely spaced that reaction products formed at each electrode diffuse to the other electrode while the potential is applied, measuring or estimating a value indicative of the change in current as a function of time and a value indicative of the steady state current, and determining from said volume, said current as a function of time, and said steady state current the concentration of reduced (or oxidised) form of the species in the liquid sample.

FOR THE PURPOSES OF INFORMATION ONLY

Codes used to identify States party to the PCT on the front pages of pamphlets publishing international applications under the PCT.

AL	Albania	ES	Spain	LS	Lesotho	SI	Slovenia
AM	Armenia	FI	Finland	LT	Lithuania	SK	Slovakia
AT	Austria	FR	France	LU	Luxembourg	SN	Senegal
AU	Australia	GA	Gabon	LV	Latvia	SZ	Swaziland
AZ	Azerbaijan	GB	United Kingdom	MC	Monaco	TD	Chad
BA	Bosnia and Herzegovina	GE	Georgia	MD	Republic of Moldova	TG	Togo
BB	Barbados	GH	Ghana	MG	Madagascar	TJ	Tajikistan
BE	Belgium	GN	Guinea	MK	The former Yugoslav Republic of Macedonia	TM	Turkmenistan
BF	Burkina Faso	GR	Greece	ML	Mali	TR	Turkey
BG	Bulgaria	HU	Hungary	MN	Mongolia	TT	Trinidad and Tobago
BJ	Benin	IE	Ireland	MR	Mauritania	UA	Ukraine
BR	Brazil	IL	Israel	MW	Malawi	UG	Uganda
BY	Belarus	IS	Iceland	MX	Mexico	US	United States of America
CA	Canada	IT	Italy	NE	Niger	UZ	Uzbekistan
CF	Central African Republic	JP	Japan	NL	Netherlands	VN	Viet Nam
CG	Congo	KE	Kenya	NO	Norway	YU	Yugoslavia
CH	Switzerland	KG	Kyrgyzstan	NZ	New Zealand	ZW	Zimbabwe
CI	Côte d'Ivoire	KP	Democratic People's Republic of Korea	PL	Poland		
CM	Cameroon	KR	Republic of Korea	PT	Portugal		
CN	China	KZ	Kazakistan	RO	Romania		
CU	Cuba	LC	Saint Lucia	RU	Russian Federation		
CZ	Czech Republic	LI	Liechtenstein	SD	Sudan		
DE	Germany	LK	Sri Lanka	SE	Sweden		
DK	Denmark	LR	Liberia	SG	Singapore		
EE	Estonia						

TITLE: METHOD AND APPARATUS FOR AUTOMATIC ANALYSIS**FIELD OF THE INVENTION**

This invention relates to a method for analysing the concentration of an analyte in a sample and to automatic analysing apparatus. The invention will be described herein with particular reference to a method and apparatus for measuring the concentration of glucose
5 or other analytes in blood but is not limited to that use.

BACKGROUND ART

In our copending applications PCT/AU/00365, PCT/AU/00723, and PCT/AU/00724 (the disclosures of which are incorporated herein by reference) we have described a method
10 for determining the concentration of an analyte in a carrier. In that method a sample to be analysed is brought into contact with a reagent containing an enzyme and a redox mediator in an electrochemical cell. The cell is a thin layer cell comprising a working electrode spaced apart from a counter electrode by a spacer which ensures that the two electrodes have substantially identical area and predetermined spacing. The spacing between the
15 electrodes is essentially close so that after a potential is applied between the electrodes, reaction products from the counter electrode migrate to the working electrode and vice versa, eventually establishing a steady state concentration profile between the electrodes which in turn results in a steady state current.

It has been found that by comparing a measure of the steady state current with the
20 time rate at which the current varies in the current transient before the steady state is achieved, the diffusion coefficient of the redox mediator can be measured as well as its concentration. It can be shown that over a restricted time range a plot a $\ln(i/i_{ss}-1)$ vs time (measured in seconds) is linear and has a slope (denoted by S) which is equal to $-4p^2D/L$, where "i" is the current at time "t", " i_{ss} " is the steady state current, "D" is the diffusion

coefficient in cm^2/sec , "L" is the distance between the electrodes in cm and "p" is the constant pi, approximately 3.14159. The concentration of reduced mediator present when the potential was applied between the electrodes is given by $-2p^2i_{ss}/FALS$, where "F" is Faraday's constant, A is the working electrode area and the other symbols are as given above. As this later formula uses S it includes the measured value of the diffusion coefficient.

Since L and the electrode area are constants for a given cell, measurement of i as a function of time and i_{ss} enable the value of the diffusion coefficient of the redox mediator to be calculated and the concentration of the analyte to be determined. In our copending application PCT/AU/00724 there are described methods suitable for mass production of cells having a substantially constant electrode separation L and electrode area A.

Currently glucose in blood samples is measured in pathology laboratories and the like by means of apparatus such the YSI blood analyser in which successive samples are analysed by means of a hollow cylindrical probe in which is mounted a silver and a platinum electrode. The face of the probe is fitted with a three layer membrane. The middle layer contains an immobilised enzyme which is sandwiched between a cellulose acetate and a polycarbonate membrane. The face of the probe, covered by the membrane, is situated in a buffer filled sample chamber into which successive samples are injected. Some of the sample diffuses through the membrane. When it contacts the immobilised oxidase enzyme it is rapidly oxidised producing hydrogen peroxide, the glucose forming a glucono-delta-lactone.

The hydrogen peroxide is in turn oxidised at the platinum anode producing electrons. A dynamic equilibrium is achieved when the rate of peroxide production and removal

reach a steady state. The electron flow is linearly proportioned to the steady state peroxide concentration and therefore to the concentration of the glucose.

The platinum electrode is held at an anodic potential and is capable of oxidising many substances other than hydrogen peroxide. To prevent these reducing agents from contribution to sensor current, the membrane contains an inner layer consisting of a very
5 thin film of cellulose acetate. This film readily passes hydrogen peroxide but excludes chemical compounds with molecular weights above approximately 200. The acetate film also protects the platinum surface from proteins, detergents, and other substances that could foul it. However the cellulose acetate film can be penetrated by compounds such as
10 hydrogen sulphide, low molecular weight mercaptans, hydroxylamines, hydrozines, phenols and analytes.

In use, the sample (or a calibration standard) is dispensed in to the chamber, diluted into 600 microlitres of buffer, and then a measurement is made by the probe. The sensor response increases and then reaches a plateau when a steady state is reached. After several
15 seconds a buffer pump flushes the chamber and the sensor response decreases.

The apparatus monitors the base line current. If it is unstable a buffer pump will continue to flush the sample chamber with buffer. When a stable base line is established an automatic calibration is initiated. The apparatus calibrates itself for example after every five samples or 15 minutes. If a difference of more than 2% occurs between the present
20 and previous calibration, the apparatus repeats the calibration. Recalibration also occurs if the sample chamber temperature drifts by more than 1°C.

The apparatus described suffers from a number of disadvantages. Firstly, a high proportion of its time in use is spent in performing calibrations rather than analysis.

Furthermore the consumption of buffer and calibrating solutions is a substantial cost.

Another disadvantage is that as the enzyme membrane ages, a graph of reading versus concentration becomes non-linear. It would be highly desirable to provide apparatus which is able to make measurements of the kind described with improved speed, efficiency, and
5 at lower running cost.

OBJECT OF THE INVENTION

An object of the present invention is an improved method and apparatus for automatically analysing samples which avoids or ameliorates at least some of the disadvantages of prior art. An object of the preferred embodiment of the invention is an
10 automatic apparatus for estimating the concentration of glucose in samples of blood.

BRIEF DISCLOSURE OF THE INVENTION

According to a first aspect the invention consists in a method for estimating the concentration of a reduced (or oxidised) form of a redox species in a liquid comprising the steps of:

- 15 (1) contacting an area of a first electrode with a sample of predetermined volume of the liquid,
- (2) contacting the sample with an area of a second electrode spaced apart from the first,
- (3) applying a potential between the electrodes while the electrodes are sufficiently closely spaced that reaction products formed at each electrode diffuse to the other electrode
20 while the potential is applied,
- (4) measuring or estimating a value indicative of the change in current as a function of time and a value indicative of the steady state current, and

(5) determining from said volume, said current as a function of time, and said steady state current, the concentration of reduced (or oxidised) form of the species in the liquid sample.

According to a second aspect the invention consists in automatic analysing apparatus
5 comprising:

a first electrode,

means for placing a drop of predetermined volume of a liquid sample in contact with
the first electrode,

means for contacting the drop with a second electrode spaced from the first,

10 means for applying a potential between the electrodes, and

means for measuring the current as a function of time while the electrodes are in
sufficiently close proximity that reaction products formed at one electrode diffuse to the
other and achieve a steady state distribution.

BRIEF DESCRIPTION OF THE DRAWINGS

15 Various embodiments of the invention will now be described by way of example
only with reference to the accompanying drawings wherein:

Figure 1 is a schematic diagram showing in cross-section a first embodiment of
apparatus according to the invention.

Figure 2 is a schematic diagram showing, in enlarged cross-section, a sample droplet
20 between two electrodes.

Figure 3 is a schematic diagram showing in cross-section a second embodiment of
apparatus according to the invention.

Figure 4 is a schematic diagram of a third embodiment of apparatus according to the
invention in side elevation.

Figure 5 shows the embodiment of figure 4 in end elevation, viewed on line 5-5 of Figure 4.

DESCRIPTION OF PREPARED EMBODIMENTS

By way of example a first embodiment of apparatus according to the invention will
5 be described.

With reference to Figure 1 there is shown schematically an automatic analyser for measuring glucose in blood samples. The apparatus comprises a flexible first electrode 1 consisting of a palladium layer 2 formed or deposited onto a flexible carrier 3 (for example a 100 micron PET film) preferably by sputter coating to a thickness of for example 100-
10 1000 angstrom. Electrode 1 is fed into the analyser from a roll (not illustrated) in the form of a tape.

First electrode 1 is provided on palladium surface 2 with an enzyme and a redox mediator. These may be selected (without limitation) from the systems in table 1 and in the present example a GOD enzyme and ferricyanide mediator are used. The enzyme and
15 redox mediator may be printed in predetermined quantities at predetermined intervals on the first electrode surface as a dried reagent coating 4.

Electrode 1 is driven by means not shown in the drawings through a sample station "S" at which a precise volume of a sample 1 is placed as a droplet 5 on a reagent coating 4 on electrode surface 1, for example, by means of an automatic pipette 6. Less preferably,
20 predetermined quantities of enzyme and redox mediator may be combined with the sample before or after deposition of the droplet on the electrode.

A second electrode 11 which in the present example is of similar construction to the first electrode, and comprising a palladium layer 12 sputter coated onto a flexible PET carrier 13, is then brought into closely spaced relationship with electrode 1 and into contact

with a droplet 5. The droplet wets both palladium surfaces 1 and 10 and adopts a substantially cylindrical configuration between the two electrodes as more clearly illustrated in Figure 2. The droplet is bounded intermediate electrodes 1, 2 by a liquid/gas interface 14.

5 An electric potential is then applied to the two electrodes (by means not illustrated in Figure 1) via contacts.

As described in our co-pending applications PCT/AU96/00723 and PCT/AU96/00724, the potential between the electrodes is set such that the rate of electro-oxidation of the reduced form of the species (or of electro-reduction of the oxidised form) is diffusion controlled. Because the working and counter electrodes are placed in very close proximity (about 0.5 mm apart or less) ferricyanide that is generated at the counter electrode has time to reach the working electrode and contribute to the current at the working electrode. That is, a ferricyanide molecule can be reduced at the counter electrode to ferrocyanide, and can then diffuse to the working electrode, where it will be re-oxidised to ferricyanide. This situation results in a decreasing current at short times that steadies to reach a constant value at longer times (the steady state current). This steadying of the current occurs because a constant stream of ferrocyanide is being supplied to the working electrode from the counter electrode. This mechanism is quite distinct from that which occurs in a Cottrell device in which the electrodes are separated so that ferricyanide that results from the reduction of ferricyanide at the counter electrode does not influence the observed current.

10
15
20

In the present cell the steady state current is given by

$$i_{ss} = \frac{2DFAC_0}{L} \quad - (1)$$

wherein i_{ss} is the steady state current, D is the diffusion coefficient, F is the Faraday constant, A is the area of the electrode, C_0 is the concentration of the analyte (ferricyanide) and L is the separation of the electrodes.

The current i at time t is given by the equation:

$$5 \quad i = i_{ss} \left(1 + 2 \sum_{n=1}^{\infty} e^{-\frac{4p^2 n^2 Dt}{L^2}} \right) \quad - (2)$$

where p is π .

At longer times the higher exponential terms in equation 2 can be ignored. Therefore equation 2 can be approximated by equation 3 for times greater than a certain value

$$i = i_{ss} \left(1 + 2 \exp\left(-\frac{4p^2 Dt}{L^2}\right) \right) \quad - (3)$$

10 If it is assumed that equation 2 can be approximated by equation 3 when the second exponential term in equation 2 is 1% of the first exponential term, equation 3 is valid for

$$\text{times greater than } t = \frac{0.0389L^2}{D}.$$

It will be understood that Equation 3 can be transformed to give:

$$15 \quad \ln\left(\frac{i}{i_{ss}} - 1\right) = \ln(2) - 4p^2 \frac{Dt}{L^2} \quad (4')$$

So a plot of the left hand side of equation (4') versus time will give a straight line with new

$$\text{slope} = -4p^2 \frac{Dt}{L^2} \quad (5')$$

20 Combining equations (1) and (5') gives

- 9 -

$$C_o = - \frac{2p^2 iss}{FV slope} \quad (6')$$

where $V = AL$ is the volume of the drop of sample pipetted onto the tape. Since the parameters "slope" and "iss" are measured in the test and p and F are universal constants, to measure the concentration of the analyte derived from the test (C_o) it is only required to
5 know the volume of the sample pipetted. Since this can be done very accurately it is possible to have a very accurate measure of C_o without the need for any other calibration of the system. Significantly, neither the spacing between the electrodes nor the electrode area wetted need be known.

The exact shape adopted by the droplet in contact with the two electrodes is not
10 important.

If desired the chemistry of successive electrode locations could be different one from another so that a multiplicity of different tests could be performed on successive pipetted volumes of sample placed at successive electrode locations. In a second embodiment as shown in Figure 3 which corresponds to the portion of Figure 1 upstream from sample
15 station S, the first electrode is provided with an overlying layer 7 for example of a thin PET film from which apertures have been punched to define wells 8 into which chemical reagents 4 can be placed, and which served to define the locations at which reagents have been placed and/or to protect the reagents prior to use. In this case electrode 1 is conveniently supplied to the apparatus from a roll having predetermined quantities of
20 chemical reagents in the wells in dried form and protected from contamination prior to use by being sandwiched between layers of the roll. The chemical reagents are only used once and therefore can be more easily protected against deterioration than is possible with prior art. In the above described embodiment the sample droplet 5 is not "contained" by a cell

although it may be deposited and located within a well 8. When a well-defining layer 7 is employed it may be adhered to the electrode surface or electrode carrier or it may merely be a non-adhered spacer layer.

It is not necessary for the upper electrode layer 11 to come into contact with the top surface of the well-defining layer 7. The volume of sample pipetted is such that the height of drop 5 is equal to or preferably greater than the thickness of the well-defining layer 7. If a layer 7 is used to define a well 8, it is undesirable for the sample volume to run to the sides of the well. It is sufficient that the sample is a known volume and wets both electrodes preferably forming a substantially cylindrical shape therebetween.

It will also be understood that the well-defining layer 7 can be replaced with a porous layer for example a porous paper, non-woven mesh, or felt, or a porous membrane, which acts to immobilise the sample spatially with respect to the electrode layers and to hold the reagents in place and in this case the second electrode will contact the surface of the porous layer immobilising the volume.

It will be understood that use of a porous or well-defining layer 7 is optional and that in other embodiments of the invention a layer 7 is unnecessary it being sufficient for a drop of sample to be pipetted onto a metal layer 2 and for an upper metal layer 12 to be brought into contact with a sample drop of predetermined volume, upper metal layer 12 being desirably but not essentially at a predetermined spacing from the lower metal layer 1.

It will also be understood that the metal layer tapes or bands need not be travelling in the same direction. For example, one metallised electrode layer may be proceeding transversely of the other, each tape being advanced after each measurement to expose a fresh lower and fresh upper electrode surface and fresh reagent at the sample filling station.

In each case the resulting current is measured as a function of time while the electrodes are in contact with a sample drop of predetermined volume.

Continuous band electrodes are preferred. These may either be disposed of after use or may be passed through a washing station and then reused, if desired after reprinting with
5 reagents.

In preferred embodiments of the invention predetermined quantities of reagent are placed on one or both of the electrodes by metering devices for example an ink jet print-head upstream of sample station 3 and may, but need not, be dried prior to contact with the sample. A reagent application system may be a part of the apparatus, or the apparatus may
10 be adapted to receive electrodes in roll or other form pretreated with the desired reagents at another location or plant.

It will be understood that one or both electrodes need not be a continuous band but may, for example, be in the form of a retractable probe. The second electrode could be a disposable probe lowered into contact with a droplet on a first electrode and then
15 withdrawn after current measurements are completed. Likewise the first electrode need not be in the form of a tape. The first electrode could for example be mounted to a carousel or be in the form of a rotating disc. Although it is preferred to use disposable electrode surfaces, the method may be applied with reusable electrodes washed in between successive uses. By way of example, there is shown schematically in Figure 4 an
20 automatic analysing apparatus comprising a first electrode 1 in the form of a first disc driven intermittently in rotation about a first horizontal axis. A second electrode 11 is driven intermittently and synchronously with the first disc in rotation about a horizontal axis parallel to the first axis. Electrodes 1 and 11 are spaced apart at their edge at the closest point of approach. Sample drops 5 of precisely predetermined volume are

deposited on the first electrode at intervals by a pipetting device 6 in synchronisation with the disc rotation. Reagents 4 are printed on the second electrode at corresponding intervals by means of a printing roll 16 and are dried in situ, for example by an air blower (not shown in the drawing).

5 In use, as electrode 1 rotates, a drop 5 travels to a position where it comes into contact with the second electrode and with the reagents printed thereupon. While both discs are stationary with the droplet in contact with each electrode, a potential is applied between the electrodes and the current measured as previously discussed. During this time the reagent(s) dissolve in the sample and after the necessary measurements have been
10 made, both electrodes are indexed to a new angle of rotation. The surfaces used for the analysis are washed clean by sprays 14, into drained sumps 15 and ready for reuse.

Apparatus according to the invention requires very much smaller samples than are required with the YSI device and because the chemical reagents can be better protected until used and more accurately metered, the apparatus provides greater accuracy and speed
15 at reduced cost.

In another embodiment of the invention the current can be followed with time after a potential has been applied between the electrodes until a predetermined time or state has been reached. The sign of the applied potential would then be reversed and analysis performed similar to that given above except with equations (3) and (4) being replaced
20 with

$$i = i_{ss} \left(1 + 4 \exp \left(-4p^2 \frac{Dt}{L^2} \right) \right) \quad (7)$$

$$\ln \left(\frac{i}{i_{ss} - 1} \right) = \ln(4) - 4p^2 \frac{Dt}{L^2} \quad (8)$$

This protocol has the advantage of being able to allow for slow processes occurring in the test. This can be done by:

a) waiting for the current to change by less than a predetermined amount per second before reversing the potential, such that any slow processes which effect the measurement are substantially complete,

or

b) using the change in the current with time before the potential is reversed to compensate for the slow processes occurring (as has been described in our earlier patent applications in relation to cells having a predefined electrode separation and area).

10 Although the invention has been described with reference to palladium electrodes, the electrodes can be of other suitable metals such as described for example in our earlier applications referred to herein. One electrode may be different from the other. The electrodes may be supported by PET as exemplified above or by other suitable insulating materials or may be self-supporting. If supported on an insulating film, it is preferred, but
15 not essential, that the metals be deposited on the film by sputter coating. Electrical contact for the application of a potential and/or for the measurement of current may be by any suitable means including clamping engagement with one end of the electrode if in the form of a tape, or by means of suitable rolling contacts, or springloaded contacts, or the like. The application of the electrical potential; the measurement of current; the calculation of
20 the concentration of analyte; the synchronous control of the movement of one electrode with respect to the other and with the deposition of sample droplets and, if required, with the deposition of reagents may be controlled by a microprocessor or the like and the results may be printed, displayed, and/or otherwise recorded by means which are well-known to those skilled in the control arts.

As will be appreciated by those skilled in the art from the teaching hereof the features of one embodiment may be combined with those of another and the invention may be embodied in other forms without departing from the concepts herein disclosed.

TABLE 1

ANALYTE	ENZYMES	REDOX MEDIATOR (OXIDISED FORM)	ADDITIONAL MEDIATOR
Glucose	GDH(pqq)	Ferricyanide	
Glucose (NAD dependent)	Glucose dehydrogenase and diaphorase	Ferricyanide	
Cholesterol	Cholesterol esterase and cholesterol oxidase	Ferricyanide	2,6-dimethyl-1,4-benzoquinone 2,5-dichloro-1,4-benzoquinone or phenazine ethosulfate
HDL cholesterol	Cholesterol esterase and cholesterol oxidase	Ferricyanide	2,6-dimethyl-1,4-benzoquinone 2,5-dichloro-1,4-benzoquinone or phenazine ethosulfate
Triglycerides	Lipoprotein lipase, glycerol kinase, and glycerol-3-phosphate oxidase	Ferricyanide or phenazine ethosulphate	Phenazine methosulfate
Lactate	Lactate oxidase	Ferricyanide	2,6-dichloro-1,4-benzoquinone
Lactate	Lactate dehydrogenase and diaphorase	Ferricyanide, phenazine ethosulfate, or phenazine methosulfate	
Lactate dehydrogenase	Diaphorase	Ferricyanide, phenazine ethosulfate, or phenazine methosulfate	
Pyruvate	Pyruvate oxidase	Ferricyanide	
Alcohol	Alcohol oxidase	Phenylenediamine	
Bilirubin	Bilirubin oxidase	1-methoxy-phenazine methosulfate	
Uric acid	Uricase	Ferricyanide	

THE CLAIMS DEFINING THE INVENTION ARE AS FOLLOWS:-

1. A method for estimating the concentration of a reduced (or oxidised) form of a redox species in a liquid comprising the steps of:
 - (1) contacting an area of a first electrode with a sample of predetermined volume of
5 the liquid,
 - (2) contacting the sample with an area of a second electrode spaced apart from the first,
 - (3) applying a potential between the electrodes while the electrodes are sufficiently
10 closely spaced that reaction products formed at each electrode diffuse to the other electrode while the potential is applied,
 - (4) measuring or estimating a value indicative of the change in current as a function of time and a value indicative of the steady state current, and
 - (5) determining from said volume, said current as a function of time, and said steady
15 state current the concentration of reduced (or oxidised) form of the species in the liquid sample.
2. A method according to claim 1 wherein the sample of predetermined volume is a droplet deposited on one of said electrodes.
3. Claim 3 is a method according to claim 1 or 2 wherein the droplet is held between
the two electrodes by surface tension.
- 20 4. A method according to any one of the preceding claims wherein at least one of the electrodes is in the form of a continuous strip.
5. A method according to any one of the preceding claims wherein at least one of the electrodes is preprinted with at least one reagent.

6. A method according to any one of the preceding claims wherein at least one electrode is covered with a layer which serves to define wells on the electrode surface.
7. An automatic analysing apparatus comprising:
 - a first electrode,
 - 5 means for placing a predetermined volume of a liquid sample in contact with the first electrode,
 - means for contacting the sample with a second electrode spaced from the first,
 - means for applying a potential between the electrodes, and
 - means for measuring the current as a function of time while the electrodes are in
 - 10 sufficiently close proximity that reaction products formed at one electrode diffuse to the other and achieve a steady state distribution.
8. Apparatus according to claim 7 wherein the volume is a drop.
9. Apparatus according to claim 7 wherein the drop is bounded by a gas/liquid interface intermediate the electrode surfaces when the current is measured.
- 15 10. Apparatus according to claim 7 or 8 wherein the predetermined volume is immobilised in a porous medium.
11. Apparatus according to any one of claims 7 to 10 wherein at least one of the electrodes is a palladium layer.
12. Apparatus according to any one of claims 7 to 10 wherein at least one electrode is
- 20 in the form of a continuous strip.
13. Apparatus according to any one of claims 7 to 10 wherein at least one electrode is on a flexible backing.

14. Apparatus according to any one of claims 7 to 13 further comprising a pipette for depositing a predetermined volume of sample in contact with the first electrode.
15. Apparatus according to any one of claims 7 to 14 further comprising means for depositing one or more reagents on one of the electrodes prior to placing the sample on
5 the electrode.

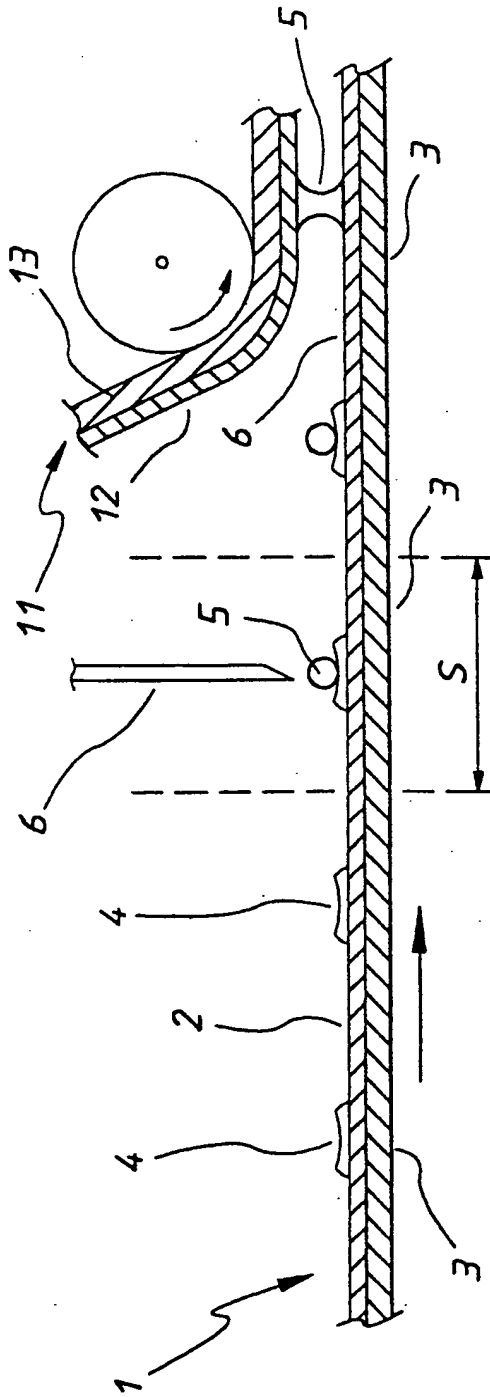

FIG. 1

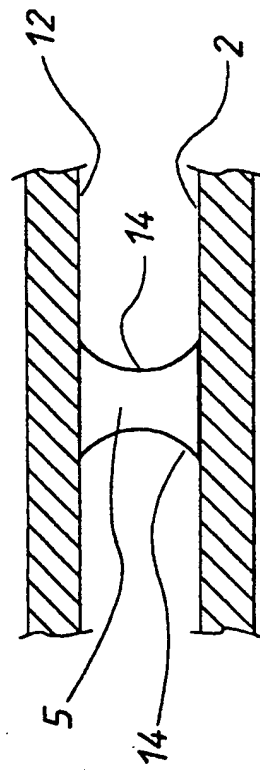

FIG. 2

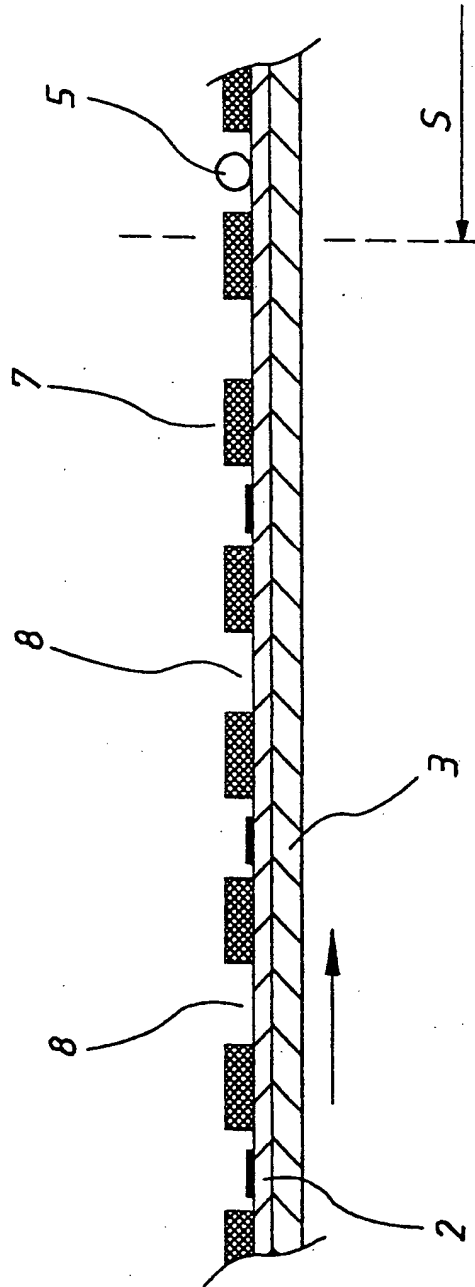
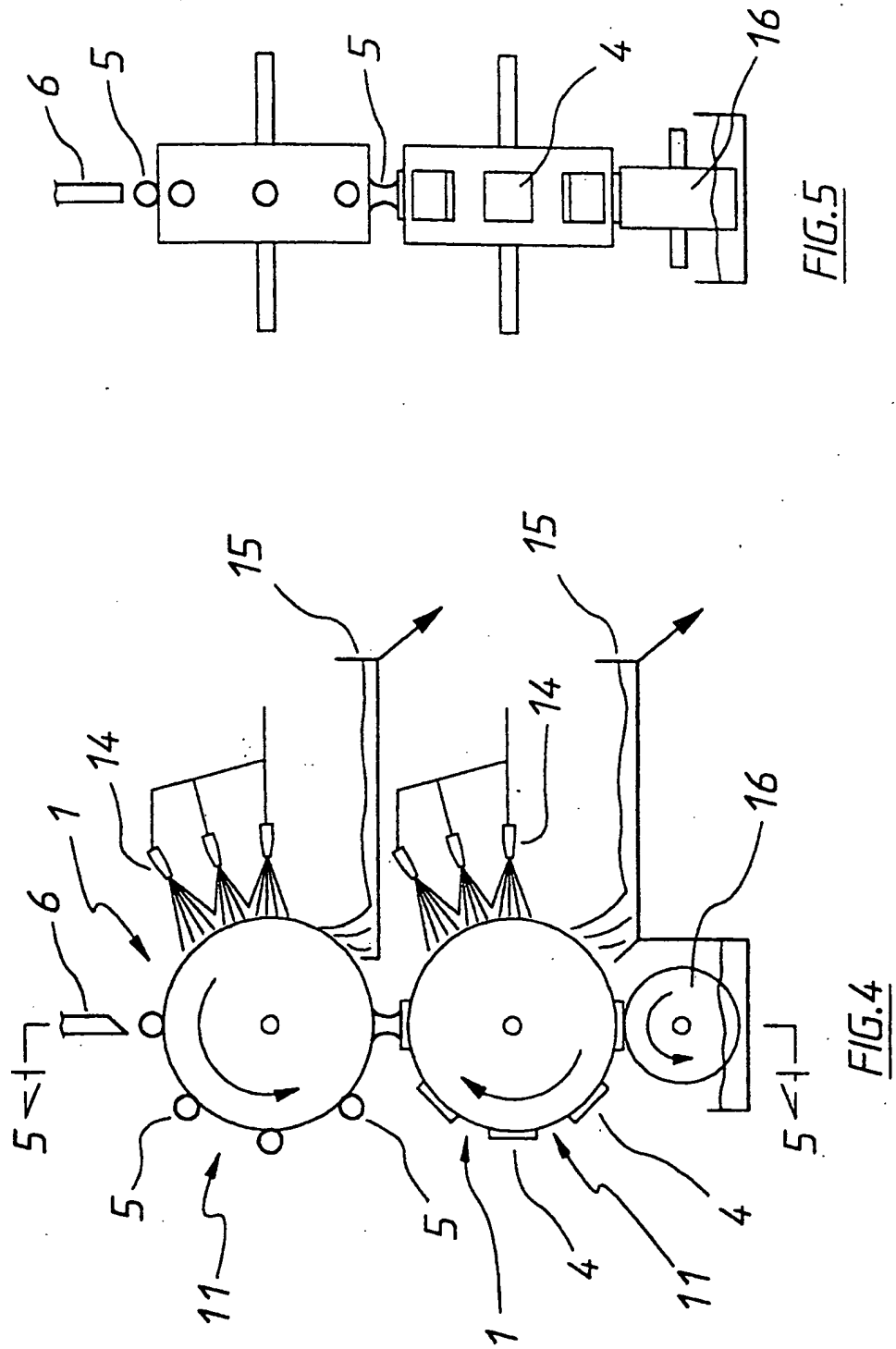

FIG.3



INTERNATIONAL SEARCH REPORT

International Application No.
PCT/AU 98/00642

A. CLASSIFICATION OF SUBJECT MATTER		
Int Cl ⁶ : G01N 27/403, 27/49, 35/02		
According to International Patent Classification (IPC) or to both national classification and IPC		
B. FIELDS SEARCHED		
Minimum documentation searched (classification system followed by classification symbols) IPC : G01N 27/26, 27/403, 27/40, 27/49, 35/00, 35/02		
Documentation searched other than minimum documentation to the extent that such documents are included in the fields searched AU : IPC as above		
Electronic data base consulted during the international search (name of data base and, where practicable, search terms used) WPAT : AUTOMATIC, CELL, CATHODE, ANODE, ELECTRODE		
C. DOCUMENTS CONSIDERED TO BE RELEVANT		
Category*	Citation of document, with indication, where appropriate, of the relevant passages	Relevant to claim No.
A	US 5322610 A (ISHIBASHI) 21 June 1994 whole document	1-15
A	AU (597433) 79650/87 (NITTEC CO LTD) 7 April 1988 whole document	1-15
<input type="checkbox"/> Further documents are listed in the continuation of Box C		<input checked="" type="checkbox"/> See patent family annex
* Special categories of cited documents:		
"A"	document defining the general state of the art which is not considered to be of particular relevance	"T" later document published after the international filing date or priority date and not in conflict with the application but cited to understand the principle or theory underlying the invention
"E"	earlier document but published on or after the international filing date	"X" document of particular relevance; the claimed invention cannot be considered novel or cannot be considered to involve an inventive step when the document is taken alone
"L"	document which may throw doubts on priority claim(s) or which is cited to establish the publication date of another citation or other special reason (as specified)	"Y" document of particular relevance; the claimed invention cannot be considered to involve an inventive step when the document is combined with one or more other such documents, such combination being obvious to a person skilled in the art
"O"	document referring to an oral disclosure, use, exhibition or other means	"&" document member of the same patent family
"P"	document published prior to the international filing date but later than the priority date claimed	
Date of the actual completion of the international search 8 September 1998	Date of mailing of the international search report 28 SEP 1998	
Name and mailing address of the ISA/AU AUSTRALIAN PATENT OFFICE PO BOX 200 WODEN ACT 2606 AUSTRALIA Facsimile No.: (02) 6285 3929	Authorized officer MEGAN BOWDEN Telephone No.: (02) 6283 2433	

INTERNATIONAL SEARCH REPORT
Information on patent family members

International Application No.
PCT/AU 98/00642

This Annex lists the known "A" publication level patent family members relating to the patent documents cited in the above-mentioned international search report. The Australian Patent Office is in no way liable for these particulars which are merely given for the purpose of information.

Patent Document Cited in Search Report		Patent Family Member					
AU	87/79650	CN	87106417	DK	2581/88	EP	282601'
		FI	882258	US	4919887	WO	8802120
US	5322601	JP	4007287				

END OF ANNEX

THIS PAGE BLANK (USPTO)